

2X KAT HULL EXTENSION KIT FOR 2X2 EXTENDED BASHER BODY (Sold Separately)

This hull extension KIT works with plastic OR aluminum 2X KAT hull

A
Drill out all parts using the Drill Guide (On Back Page)

B
Replace / Install parts shown

C
Assemble using stock 2X parts



#8 x 1" Pan (12)



#6 x 5/8" Flat (14)



6-32 Lock Nut (2)



#6 Washer (4)

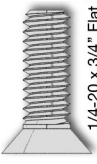

1/4-20 x 3/4" Flat Head (2)



6-32 x 3/4" Pan (2)



#8 Washer (12)



1/4-20 Lock Nut (2)

1/4-20 Locknut
6-32 x 3/4" Pan

#6 x 5/8" Flat

#6 x 5/8" Flat

#8 x 1" Pan

D

Assemble new brackets

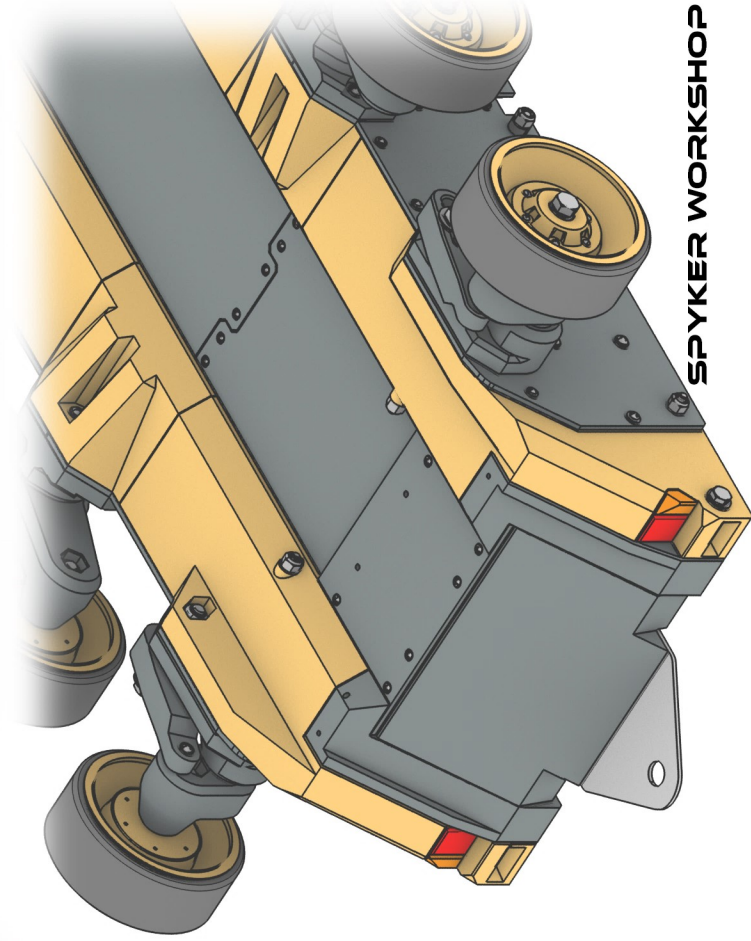
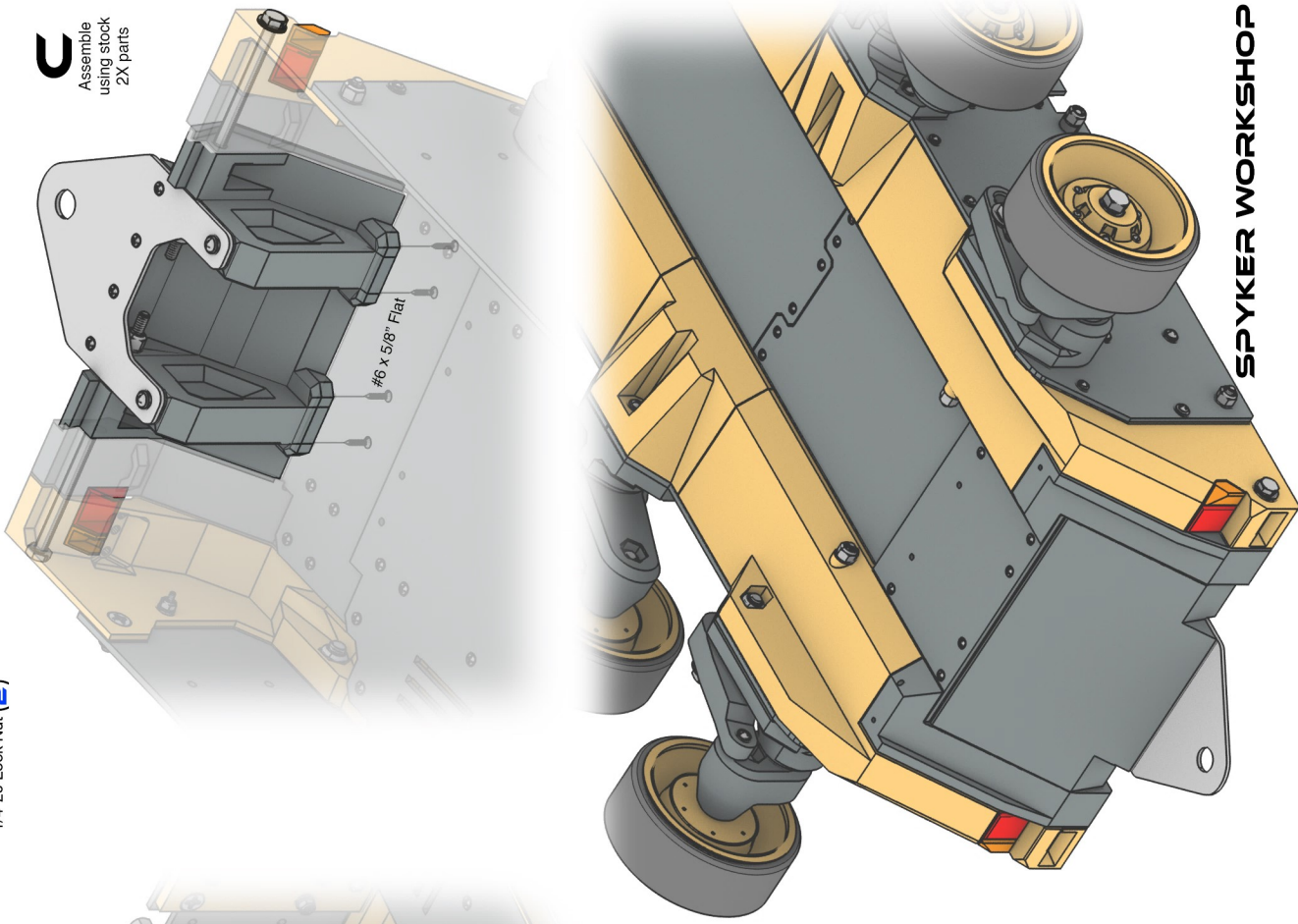

HULL EXTENSION DRILL GUIDE

DRILL SIZE KEY

▽ = Drill Hole & Countersink

○ = Drill Hole

● - 5/64" (2.0mm)

● - 3/32" (2.4mm)

● - 1/8" (3.2mm)

● - 9/64" (3.6mm)

● - 11/64" (4.4mm)

● - 1/4" (6.6mm)

● - 3/8" (9.6mm)

Drill with the sizes shown to avoid splitting or stripping out threads.

▽ = Countersink + Drill

5mm Drill For LED's

5mm Drill For LED's

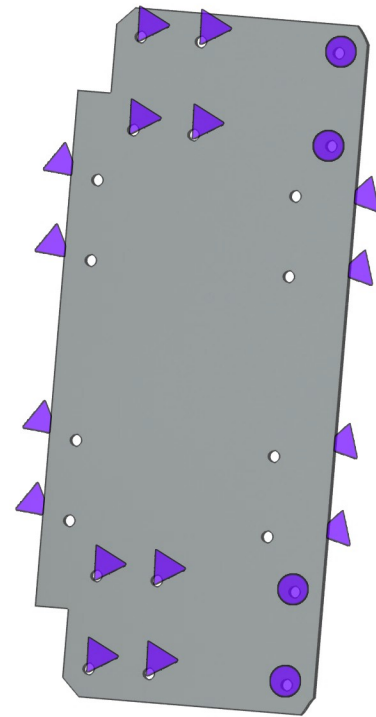
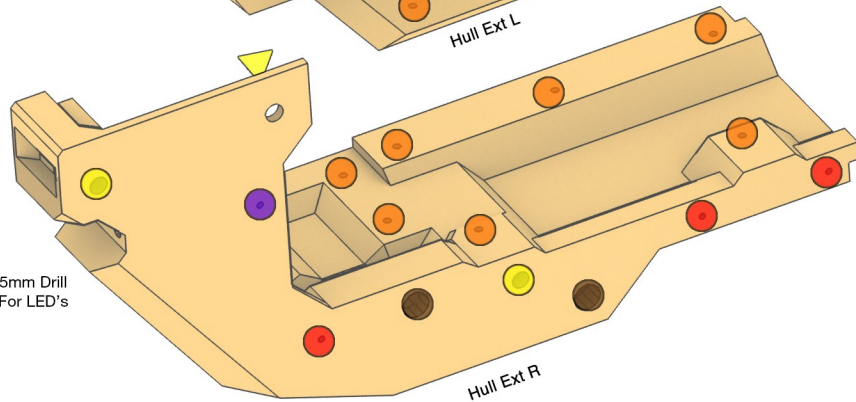
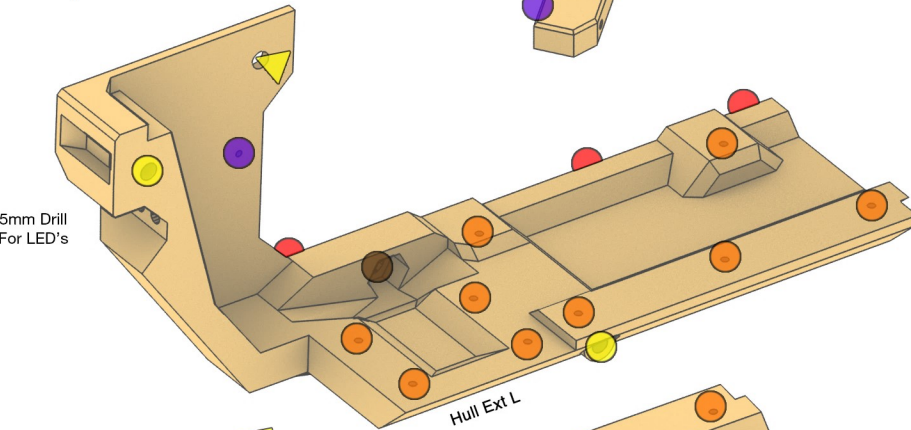
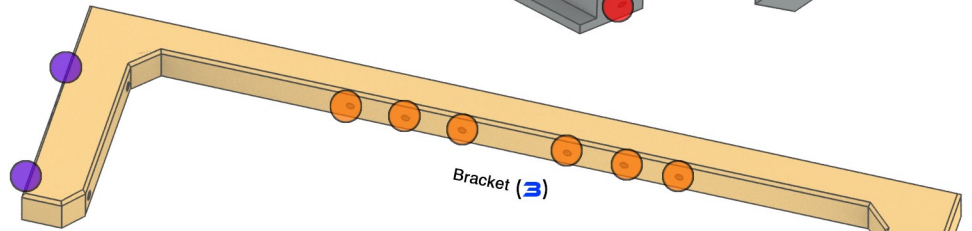
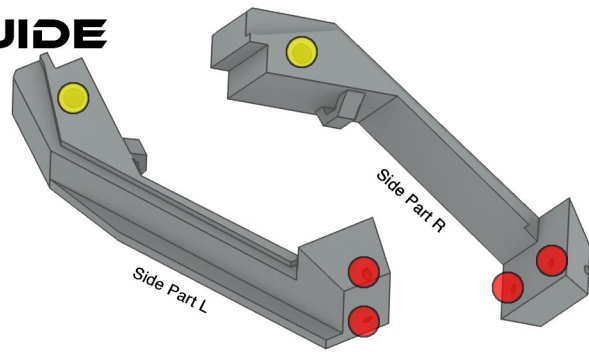

2X SPYKER KAT + HULL EXTENSION + EXTENDED BASHER BODY

Combine the hull extension KIT and extended basher body to hold massive batteries!

Able to fit golf cart sized lithium packs + more!

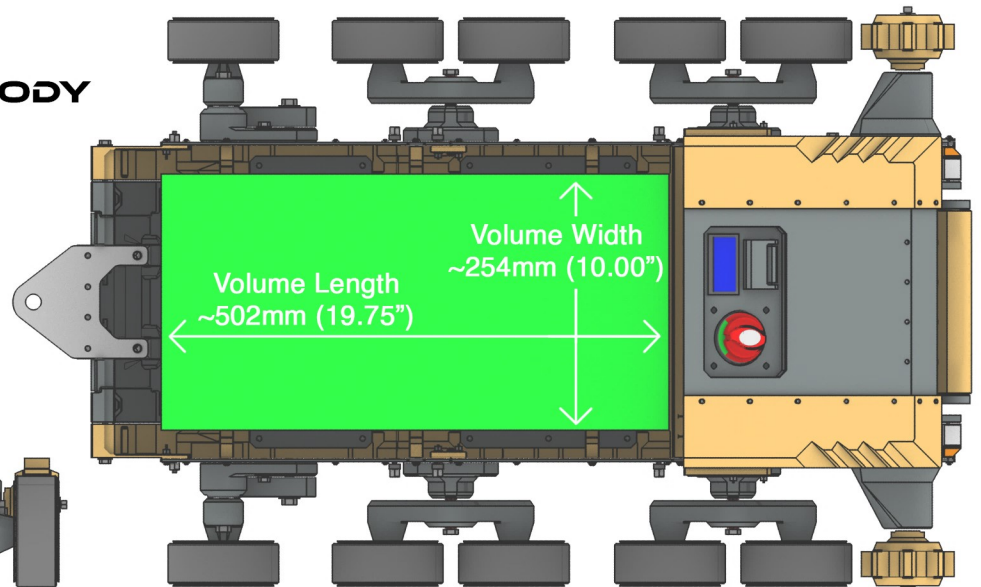
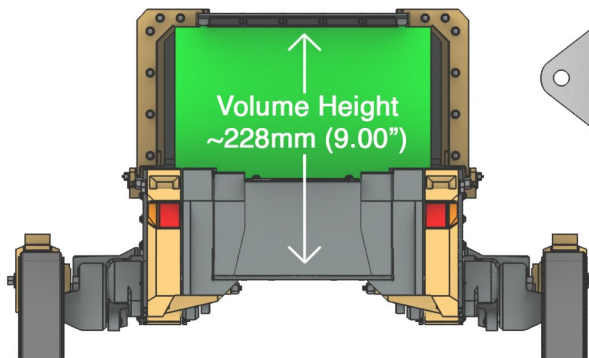

Total Internal Dimensions: 502mm (19.75") L x 254mm (10.00") W x 228mm (9.00") T

SPYKER WORKSHOP