

NEW 2X2 ELECTRONICS TRAY

GUIDE FOR NEW 2X SPYKER KAT ELECTRONICS

DRILL SIZE KEY

- ▽ = Drill Hole & Countersink
- = Drill Hole
- - 3/32" (2.4mm)
- - 1/8" (3.2mm)

EXTENDED BASHER BODY
REQUIRED to fit tray inside
(sold separately)

A

Drill with the sizes shown to avoid splitting or stripping out threads.

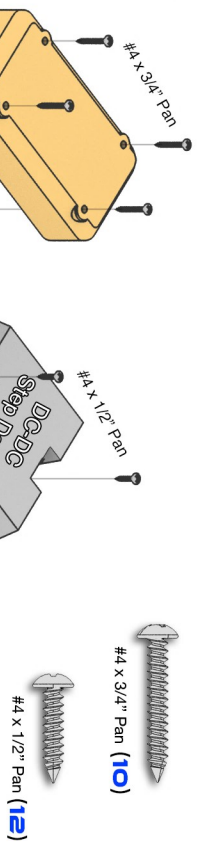
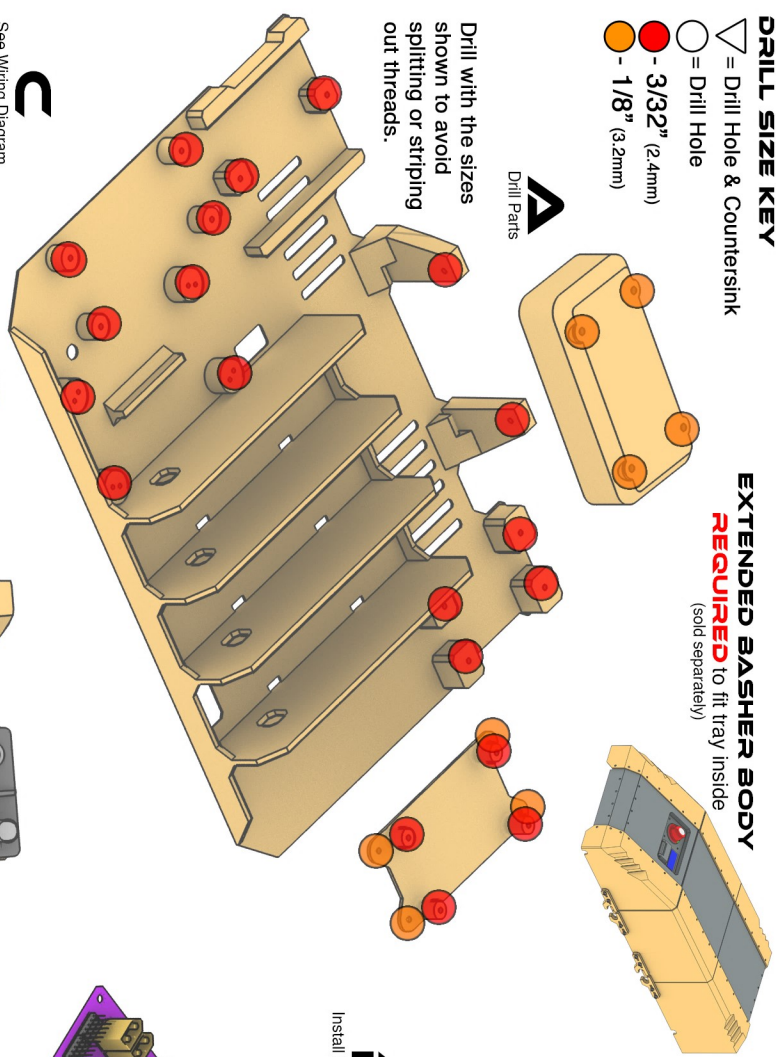

B

Install Electronics

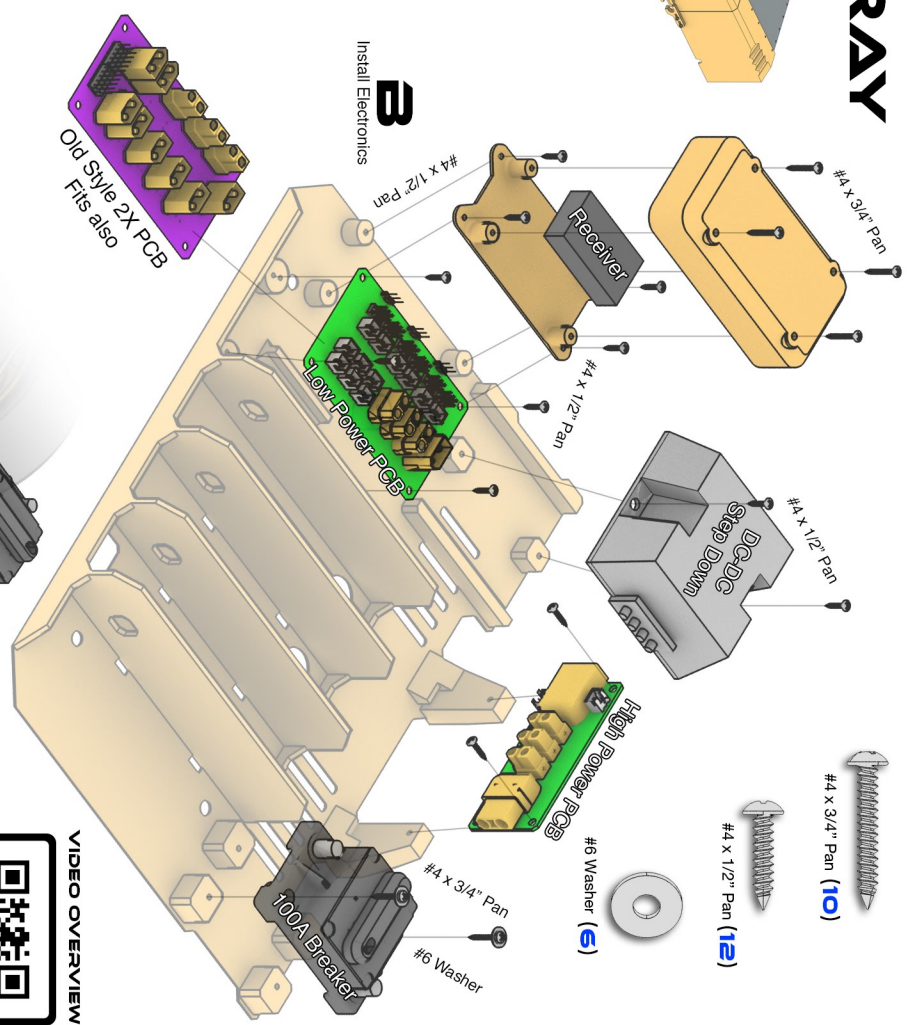

C

See Wiring Diagram to connect everything

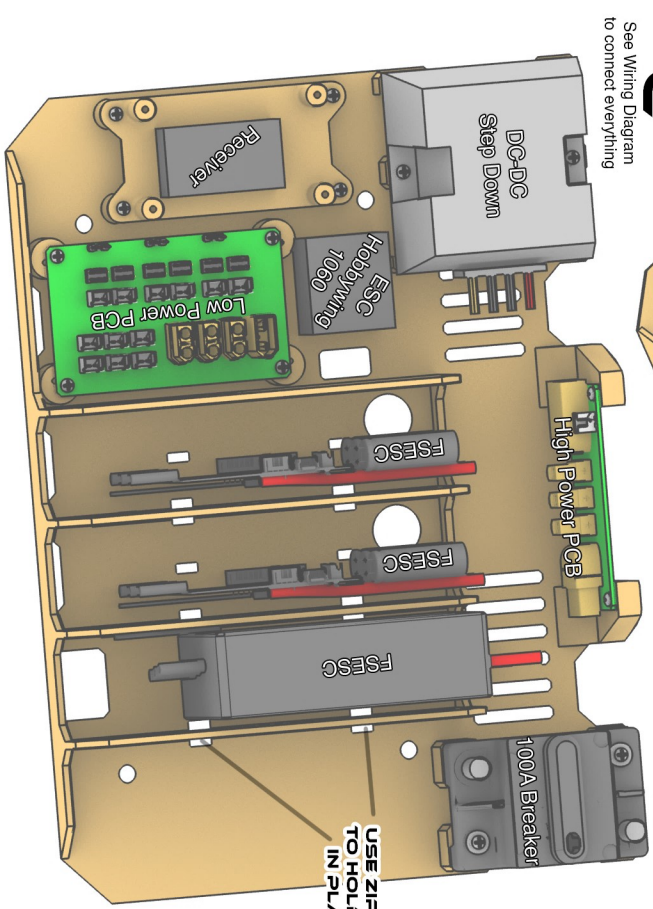

D

Mount To 2X KAT

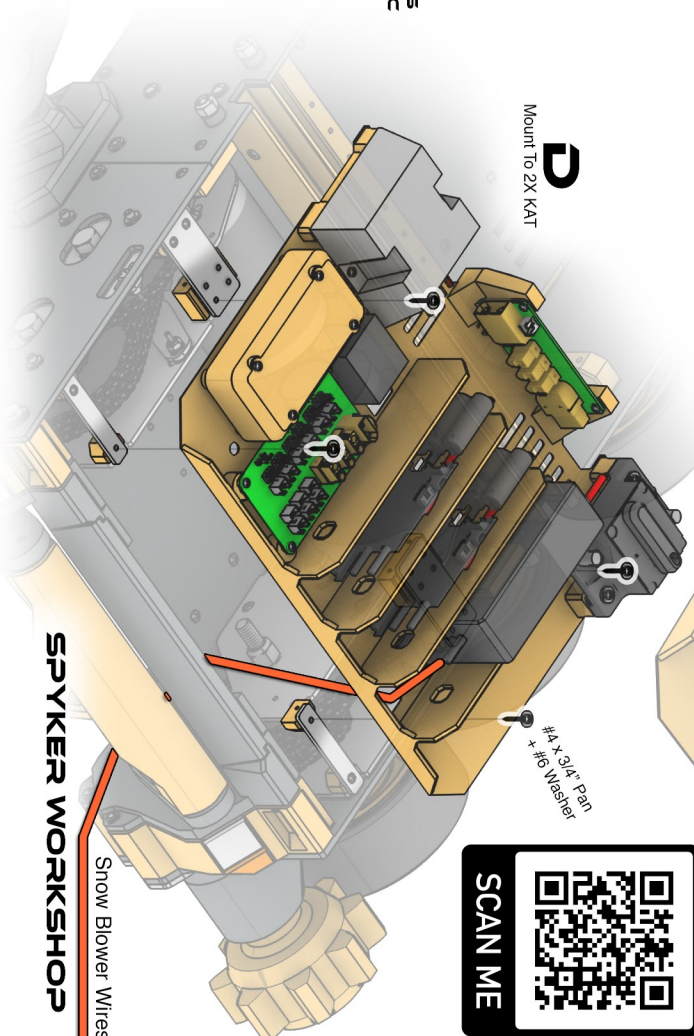

VIDEO OVERVIEW

SCAN ME

NEW 2X2 ELECTRONICS GUIDE

GUIDE FOR NEW 2X SPYKER KAT ELECTRONICS
(REQUIRES PRINTED TRAY, PCB'S ETC.)

SELECT POWER SOURCE

GOLF CART LITHIUM BATTERY
100A + DISCHARGE RECOMMENDED



*Requires Extended Basher Body + 2X KAT Hull Extension
Max Size: 502mm (19.75") L x 254mm (10.00") W x 228mm (9.00") T

EXTENDED BASHER BODY
REQUIRED to fit tray inside
(sold separately)

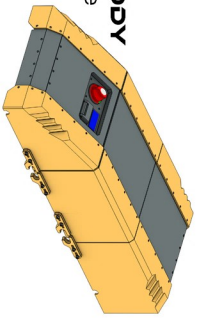

FRONT PANEL MOUNT

XT190 Panel Mount
(Used for charging + external connections)

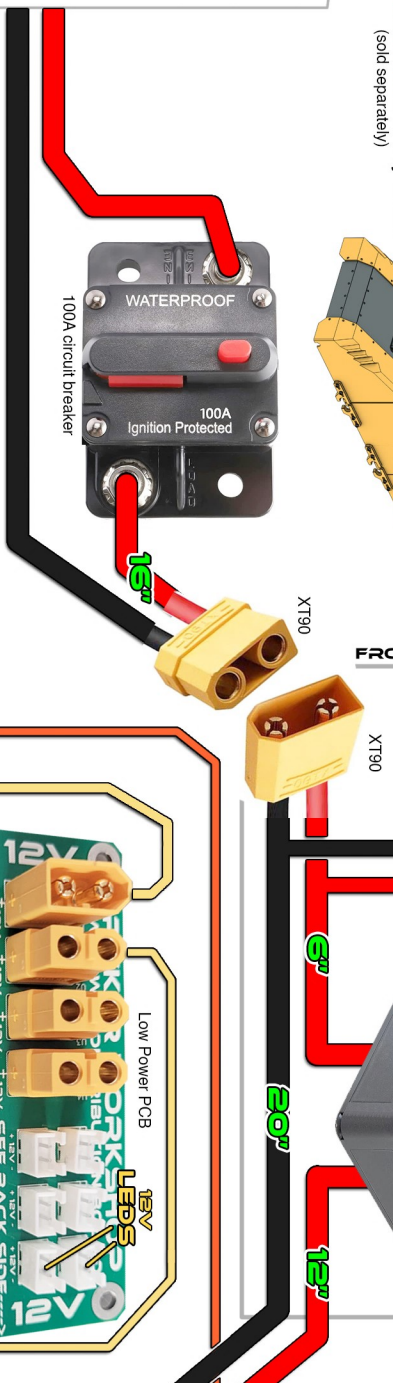

CUSTOM LITHIUM ION BATTERY DIY
24V-50V
6-13S
~20-50AH

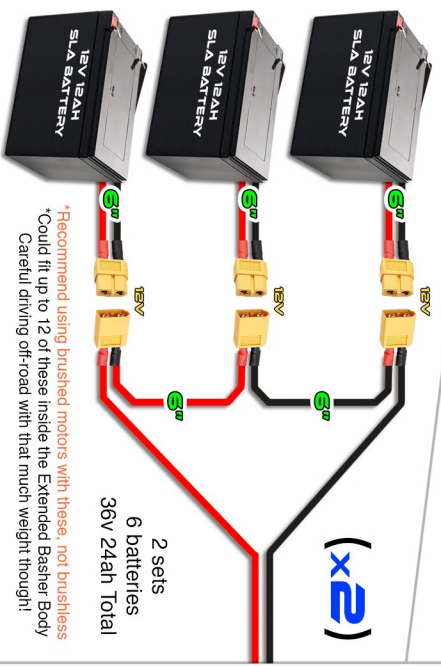

*Recommend using brushed motors with these, not brushless
*Could fit up to 12 of these inside the Extended Basher Body
*Careful driving off-road with that much weight though!

***IF NOT USING OUR PCB**
REMOVE THE RED WIRE FROM ALL OTHER ESC'S ONLY ONE ESC SHOULD SUPPLY POWER TO THE RECEIVER!
(LET HOBBYING 1060 SUPPLY POWER)

36-48V to 12V DC-DC step down converter

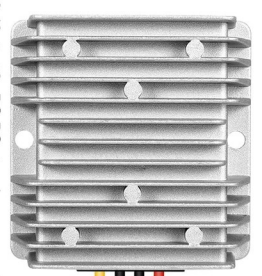

IN-LINE FUSE
5-10A



Receiver



Servo Cables
(x3)

THIS PCB ISOLATES 5V FOR MORE DETAILS ON THIS PCB CHECKOUT THIS VIDEO HERE!



SCAN ME

Splice all the lights together into one
Connect to 12V

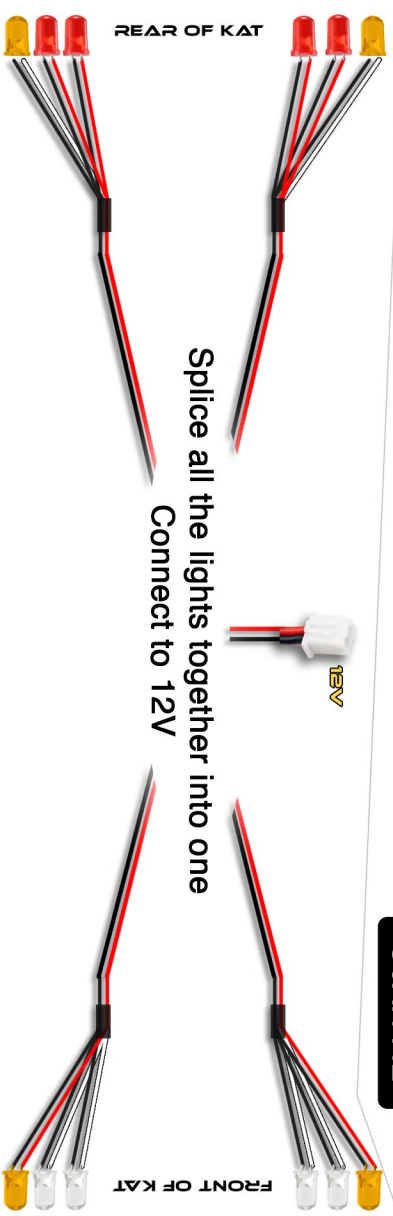

**NO EXTRA WIRE NEEDED
SOLDER PLUGS DIRECTLY ONTO EACH ITEM**

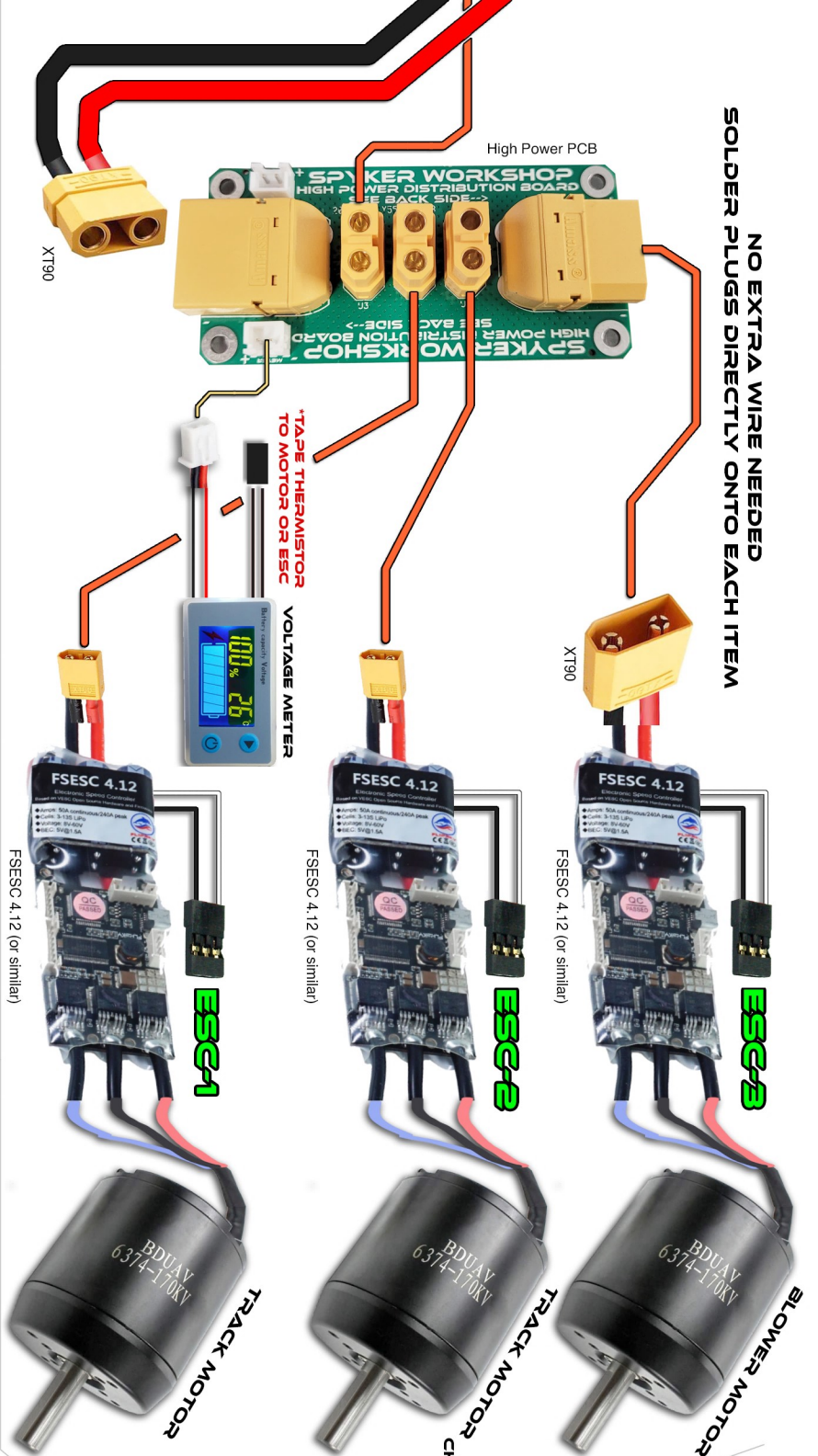

CHUTE ROTATION SERVO

- ***CONVERT TO 360 DEGREE
- ***REMOVE POTENTIOMETER
- ***REMOVE STOP ON GEAR
- ***WIRE DIRECTLY TO MOTOR***

FOR HELP SETTING UP
ESC CONTROLLERS
CHECKOUT THIS VIDEO HERE!

